



Product / Technical Information

LAMBDA SENSORS

UNIVERSAL APPLICATIONS

OPTIMUM PERFORMANCE

Includes new
Premium Sensors range

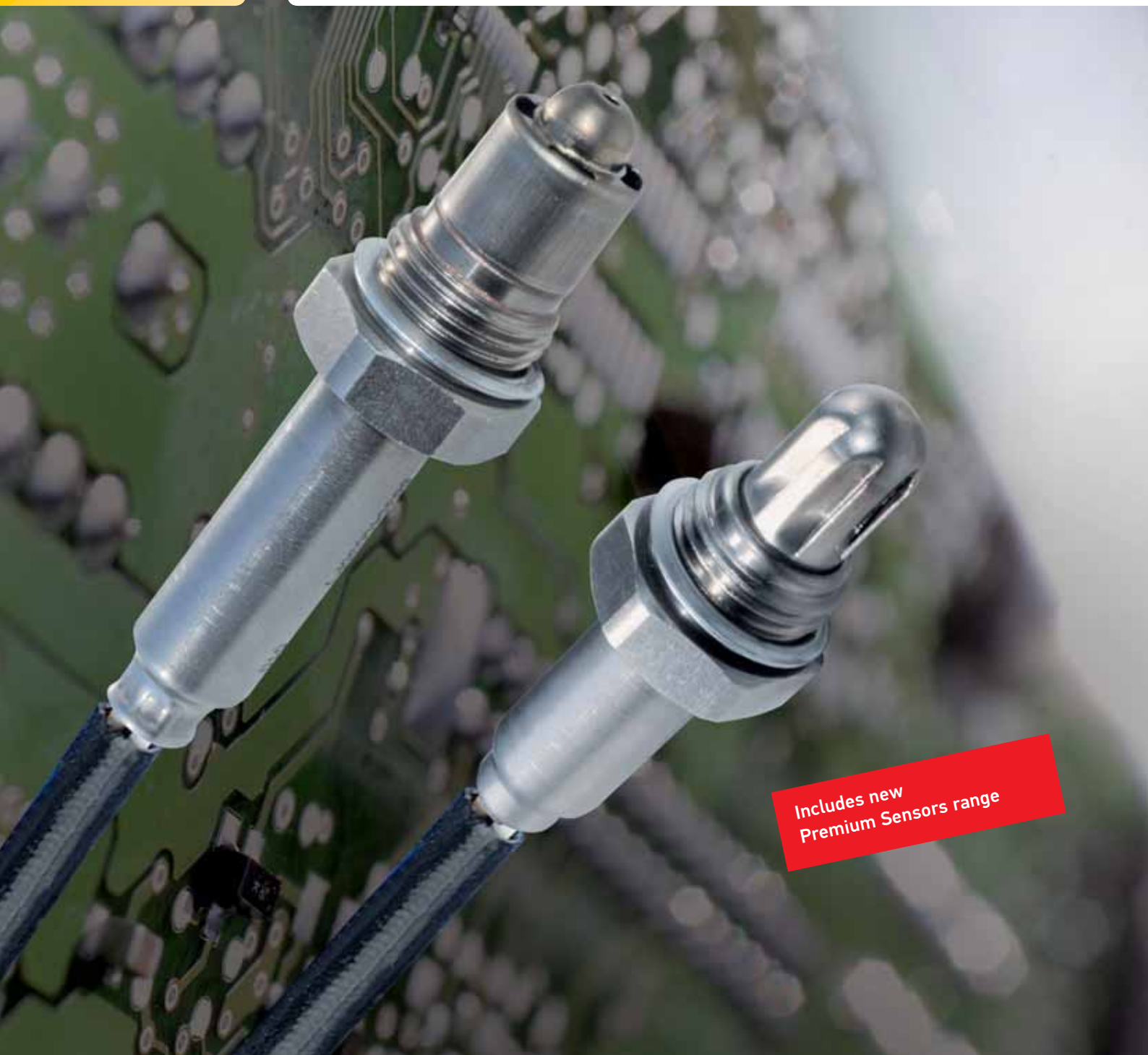

HELLA LAMBDA SENSORS

Lambda Sensors detect and measure the presence of oxygen in exhaust gases. It then compares this information with the air sample found inside the sensor. This information is relayed to the fuel injection control unit (computer) in order to calculate the optimal air/fuel ratio mix.

Dear customer:

This HELLA Lambda Sensor brochure, provides a technical specification overview for universal applications.

Apart from technical specification we also include assembly and wiring reference in a simplified manner.

The Lambda Sensor is one of the most important sensors in the engine management system. This sensor is critical and serves to control the air/fuel ratio, making it possible for vehicles to comply with the emissions standards set by law worldwide.

We trust you will find this brochure informative and enhance your understanding of how HELLA Lambda Sensors function.

**Your HELLA Automotive
South Africa Team**

The fuel injection control unit (computer) does not use the sensor signal when:

- The engine is cold, because during this period the mixture will be rich.
- In fast acceleration or in full load.
- During cut-off, as the mixture will be poor.

FUNCTIONING

The Lambda Sensor generates millivolts according to the quantity of oxygen in the exhaust gases.

The "heart" of the Lambda Sensor is the thimble shaped part made of a ceramic material called zirconium dioxide.

This thimble shaped part is also covered on both sides with an extremely thin layer of microporous platinum. This part works as a galvanic cell (battery). When the zirconium dioxide is heated to above 300°C (572°F) it becomes an electrical conductor, allowing the oxygen ions to move from the internal platinum layer (in contact with the atmosphere) to the external platinum layer (in contact with the exhaust gases).

The generation of a high millivoltage means that practically all oxygen that was injected in the combustion chamber has been consumed.

On the other hand, the generation of a low millivoltage means that there is more oxygen in the combustion chamber than is needed for combustion, leading to a surplus of oxygen in the exhaust gases.

The fuel injection control unit registers the generated millivoltage and adjusts the air/fuel mixture to be as close to the ideal ratio as possible.

GASES CREATED DURING COMBUSTION

H₂O = water
CO₂ = carbon dioxide
NO_x = nitrogen oxide
CH₄ = methane
CO = carbon monoxide
H₂ = hydrogen
HC = hydrocarbons
SO_x = sulfur oxide
N₂ = nitrogen

MAIN COMPONENTS

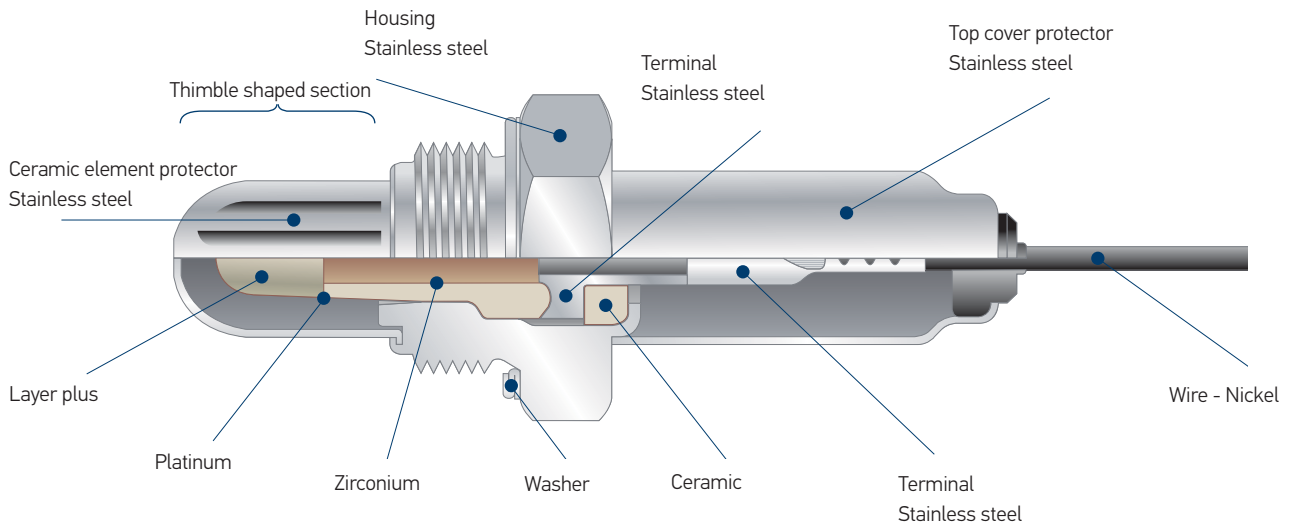

CHEMICAL CONSTITUTION

Zirconium Dioxide (ZrO₂).

SWITCHING

The transition of the Lambda Sensor output signal from a rich to lean mixture is called switching.

RICH MIXTURE

When an engine runs on a RICH mixture very little oxygen will be found in the exhaust gases. This is due to almost all the oxygen having been consumed in the combustion of the excess injected fuel. The result will be a low quantity of oxygen ions in the external electrode leading to a higher voltage generation.

LEAN MIXTURE

On the other hand, when the engine runs on a LEAN mixture, more oxygen will be found in the exhaust gases. This is due to the lack of fuel to burn all the injected oxygen. This will lead to a higher number of oxygen ions in the external electrode, resulting in the generation of a smaller voltage.

OUTPUT SIGNAL

From 0 to 1.1 volts (0 to 1 100 millivolts).

RICH MIXTURE $\lambda < 1$ More than 0.45 volts (450 mV) = Excess of fuel.

LEAN MIXTURE $\lambda > 1$ Less than 0.45 volts (450 mV) = Excess of oxygen.

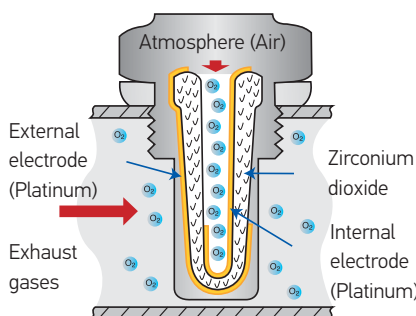
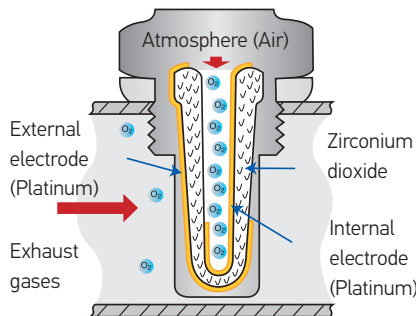

TECHNICAL SPECIFICATIONS

FREQUENCY

100 ms to 350°C (662 °F) – 50 ms to 800°C (1 472 °F)

INITIAL WORKING TEMPERATURE

300°C (572 °F) without internal heating
150°C (302 °F) with internal heating

INPUT VOLTAGE OF THE HEATER

12 to 14 volts

THREAD

M18 x 1.5

HEXAGONAL

22 mm

TORQUE

40 to 60 Nm

MAXIMUM WORKING TEMPERATURE

1 000 °C (1 832 °F)

STOCK KEEPING TEMPERATURE

-40 °C to 100 °C (-40 °F to 212 °F)

MAINTENANCE CHECK

30 000 km or 1 year

WHY HELLA LAMBDA SENSORS - UNIVERSAL APPLICATIONS

The replacement of a used Lambda Sensor ensures the optimal air/fuel mix ratio during the combustion process. Therefore in most cases, significant lower fuel consumption is evident:

- Saving money and fuel
- Inhibits environmental impact
- Reduces wear and tare as well as repair expenses

Key benefits of HELLA Lambda Sensors include:

- Only 6 different part numbers cover the majority of vehicles in the car parc
- Lower expenses on capital commitment
- Universal parts are generally less expensive than vehicle specific parts (You get the same technology and quality under the HELLA banner.)

TROUBLESHOOTING

There are a number of issues to consider when a troubleshooting problems, including, poor fuel quality, short circuit from signal to negative or ground, wire corrosion and/or solvents or detergents in the exhaust system. Furthermore:

- Check whether there is any damage to the main body, wires or the plug
- Due to its proximity to the exhaust system, poor fitting may cause the plug or wire covers to melt, which results in the need to replace the sensor
- Other physical damage to the sensor body, water ingress or loosening of cable seals
- The sensor element can also be affected by chemicals which should not be present in the vehicles emissions

In each case, the problem should be rectified and the sensor replaced.

The following pictures show how chemicals, which should not be present in the fuel system, as well as engine damage, can detrimentally affect the sensors.



Rich fuel mixture



Silicon poisoning



Lead poisoning



Coolant / anti-freeze contamination



High oil consumption

NOTE: Lambda Sensors cannot be cleaned / restored / repaired following contamination or damage.

COLOUR WIRE ASSEMBLY TABLE OEM | UNIVERSAL

Universal lambda colour wire index:		Caution!			
A Signal (Black)		Before replacing a Lambda Sensor always check type and resistance.	Sensor Type	Value resistance (Ohms)	Universal Lambda Sensor
B Ground (Grey)			Finger	3 - 6	LS7773 / LS7003
C Heater (White)			Planar	9 - 10	LS7774 / LS7004
D Heater (White)		See chart on right. →			LS8884 / LS8004

Note: The heater is not polarity dependent.

General Motors							
Black	→	Black	A	Purple	→	Black	A
Orange	→	Grey	B	Orange	→	Grey	B
Purple	→	Black	A	Black	→	Black	A
Black	→	White	C	Brown	→	White	C
Pink	→	White	D	Brown	→	White	D
Purple	→	Black	A	Purple	→	Black	A
Black	→	White	C	Pink	→	White	C
Black	→	White	D	Pink	→	White	D
Purple	→	Black	A	Purple	→	Black	A
Orange	→	Grey	B	Pink	→	White	C
Brown	→	White	C	Pink	→	White	D
Brown	→	White	D	Black	→	Black	A
Purple	→	Black	A	Orange	→	Grey	B
Orange	→	Grey	B	Pink	→	White	C
Brown	→	White	C	Pink	→	White	D
Brown	→	White	D	Purple	→	Black	A
Purple	→	Black	A	Yellow	→	Grey	B
Orange	→	Grey	B	Brown	→	White	C
Pink	→	White	C	Brown	→	White	D
Pink	→	White	D	Brown	→	White	D
Purple	→	Black	A	Black	→	Black	A
Orange	→	Grey	B	Grey	→	Grey	B
Brown	→	White	C	White	→	White	C
Brown	→	White	D	Purple	→	White	D
Purple	→	Black	A	Black	→	Black	A
Orange	→	Grey	B	Grey	→	Grey	B
Pink	→	White	C	White	→	White	C
Pink	→	White	D	Purple	→	White	D
Blue	→	Black	A	White	→	Black	A
Green	→	Grey	B	Blue	→	Grey	B
Black	→	White	C	Black	→	White	C
Black	→	White	D	Black	→	White	D
White	→	Black	A	Black	→	White	D
Blue	→	Grey	B	White	→	Black	A
Black	→	White	C	Green	→	Grey	B
Yellow	→	White	D	Black	→	White	C
Black	→	White	D	Black	→	White	D
Blue	→	Black	A	Black	→	White	D
Green	→	Grey	B	White	→	Black	A
Black	→	White	C	Black	→	Grey	B
Black	→	White	D	Black	→	White	C
White	→	Black	A	Black	→	White	D
Blue	→	Grey	B	Yellow	→	Black	A
Black	→	White	C	White	→	Grey	B
Yellow	→	White	D	Black	→	White	C
Black	→	White	D	Black	→	White	D
Blue	→	Black	A	Black	→	White	D
Green	→	Grey	B	Black	→	White	D
Black	→	White	C	Black	→	White	D
Black	→	White	D	Black	→	White	D
White	→	Black	A	Black	→	White	D
Blue	→	Grey	B	Black	→	White	D
Black	→	White	C	Black	→	White	D
Yellow	→	White	D	Black	→	White	D
Black	→	White	D	Black	→	White	D
Blue	→	Black	A	Black	→	White	D
Green	→	Grey	B	Black	→	White	D
Black	→	White	C	Black	→	White	D
Black	→	White	D	Black	→	White	D
White	→	Black	A	Black	→	White	D
Blue	→	Grey	B	Black	→	White	D
Black	→	White	C	Black	→	White	D
Yellow	→	White	D	Black	→	White	D
Black	→	White	D	Black	→	White	D
Blue	→	Black	A	Black	→	White	D
Green	→	Grey	B	Black	→	White	D
Black	→	White	C	Black	→	White	D
Black	→	White	D	Black	→	White	D
White	→	Black	A	Black	→	White	D
Blue	→	Grey	B	Black	→	White	D
Black	→	White	C	Black	→	White	D
Yellow	→	White	D	Black	→	White	D
Black	→	White	D	Black	→	White	D
Blue	→	Black	A	Black	→	White	D
Green	→	Grey	B	Black	→	White	D
Black	→	White	C	Black	→	White	D
Black	→	White	D	Black	→	White	D
White	→	Black	A	Black	→	White	D
Blue	→	Grey	B	Black	→	White	D
Black	→	White	C	Black	→	White	D
Yellow	→	White	D	Black	→	White	D
Black	→	White	D	Black	→	White	D
Blue	→	Black	A	Black	→	White	D
Green	→	Grey	B	Black	→	White	D
Black	→	White	C	Black	→	White	D
Black	→	White	D	Black	→	White	D
White	→	Black	A	Black	→	White	D
Blue	→	Grey	B	Black	→	White	D
Black	→	White	C	Black	→	White	D
Yellow	→	White	D	Black	→	White	D
Black	→	White	D	Black	→	White	D
Blue	→	Black	A	Black	→	White	D
Green	→	Grey	B	Black	→	White	D
Black	→	White	C	Black	→	White	D
Black	→	White	D	Black	→	White	D
White	→	Black	A	Black	→	White	D
Blue	→	Grey	B	Black	→	White	D
Black	→	White	C	Black	→	White	D
Yellow	→	White	D	Black	→	White	D
Black	→	White	D	Black	→	White	D
Blue	→	Black	A	Black	→	White	D
Green	→	Grey	B	Black	→	White	D
Black	→	White	C	Black	→	White	D
Black	→	White	D	Black	→	White	D
White	→	Black	A	Black	→	White	D
Blue	→	Grey	B	Black	→	White	D
Black	→	White	C	Black	→	White	D
Yellow	→	White	D	Black	→	White	D
Black	→	White	D	Black	→	White	D
Blue	→	Black	A	Black	→	White	D
Green	→	Grey	B	Black	→	White	D
Black	→	White	C	Black	→	White	D
Black	→	White	D	Black	→	White	D
White	→	Black	A	Black	→	White	D
Blue	→	Grey	B	Black	→	White	D
Black	→	White	C	Black	→	White	D
Yellow	→	White	D	Black	→	White	D
Black	→	White	D	Black	→	White	D
Blue	→	Black	A	Black	→	White	D
Green	→	Grey	B	Black	→	White	D
Black	→	White	C	Black	→	White	D
Black	→	White	D	Black	→	White	D
White	→	Black	A	Black	→	White	D
Blue	→	Grey	B	Black	→	White	D
Black	→	White	C	Black	→	White	D
Yellow	→	White	D	Black	→	White	D
Black	→	White	D	Black	→	White	D
Blue	→	Black	A	Black	→	White	D
Green	→	Grey	B	Black	→	White	D
Black	→	White	C	Black	→	White	D
Black	→	White	D	Black	→	White	D
White	→	Black	A	Black	→	White	D
Blue	→	Grey	B	Black	→	White	D
Black	→	White	C	Black	→	White	D
Yellow	→	White	D	Black	→	White	D
Black	→	White	D	Black	→	White	D
Blue	→	Black	A	Black	→	White	D
Green	→	Grey	B	Black	→	White	D
Black	→	White	C	Black	→	White	D
Black	→	White	D	Black	→	White	D
White	→	Black	A	Black	→	White	D
Blue	→	Grey	B	Black	→	White	D
Black	→	White	C				



EXCLUSIVE FEATURES

HELLA LAMBDA SENSOR ASSEMBLY INSTRUCTIONS (UNIVERSAL APPLICATIONS)

MOST COMMON DEFECTS

- Exaggerated fuel consumption
- Loss of power
- Failure in the ignition system
- Damaged catalytic converter
- High level of hydrocarbons
- Fuel tank over-filled » damages the canister and causes rich mixture
- Crack in the ceramic thimble caused by accidental drop of the sensor

Loss of signal can be caused by:

- Use of welding in the connection of the Universal Lambda Sensor
- Terminal or connection plug problems

REPLACEMENT AND INSTALLATION

Remove the old Lambda Sensor carefully / thread corrosion or oxidation can prove problematic. Use high temperature grease in the thread of the new Lambda Sensor, so it can easily be removed later.

Avoid hitting or dropping the Lambda Sensor because the ceramic parts can be damaged.

1 Disconnect the used sensor and remove it from the exhaust system.

2 Cut the used sensor wires close to sensor's body.

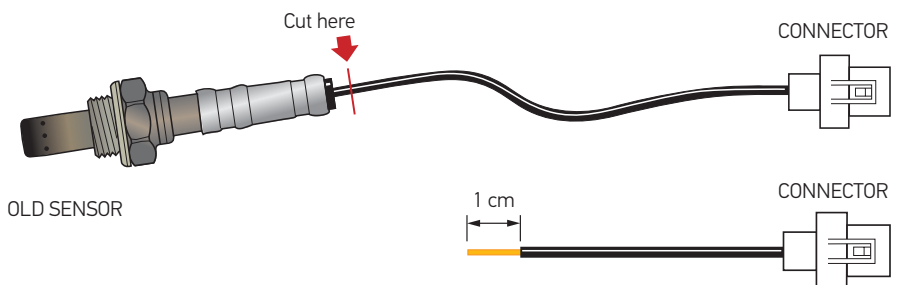

3 Remove the wire insulation (approximately 1 cm from the end of the wire).

4 Pass the plastic tube through the wire and make the connection to the new Sensor using the provided clip.

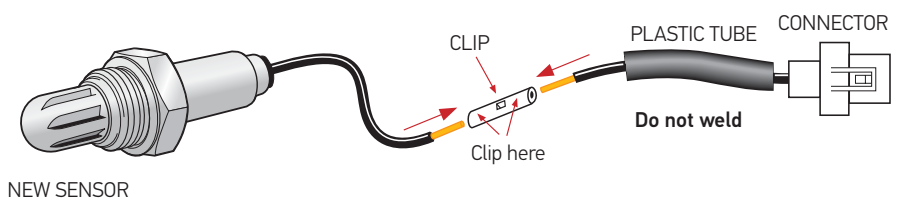

5 For ease of reference please check the wire color assembly table on page 5.

6 After making the connection, slide the plastic tube over the clip and heat it carefully using a match or a lighter until it shrinks and completely covers the connection.

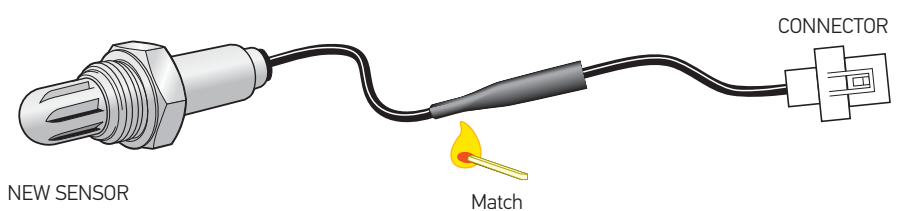

7 This procedure should be repeated for all the wires of the sensor.

HELLA UNIVERSAL LAMBDA SENSOR RANGE

GENERAL INFORMATION

Thread	M18x1.5	Maximum working temperature	1 000°C
Hex	22 mm	Torque	40 - 60 Nm
Initial working temperature	300°C without internal heater 150°C with internal heater	Input Voltage of the heater	12 to 14 volts
		Stock keeping conditions	Temperature: -40°C to 100°C Humidity: 0 to 60%

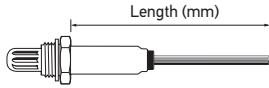

Short Code	LS7771
Part Number	3MT-007771-001
Description	UNIVERSAL Lambda Sensor
Type	Finger
No. of Wires	1
Cable Length	200 mm



Short Code	LS7772
Part Number	3MT-007772-001
Description	UNIVERSAL Lambda Sensor
Type	Finger
No. of Wires	2
Cable Length	200 mm



Short Code	LS7773
Part Number	3MT-007773-001
Description	UNIVERSAL Lambda Sensor
Type	Finger
No. of Wires	3
Cable Length	200 mm
Heater Resistance	3 - 6 Ohm



Short Code	LS7774
Part Number	3MT-007774-001
Description	UNIVERSAL Lambda Sensor
Type	Finger
No. of Wires	4
Cable Length	200 mm
Heater Resistance	3 - 6 Ohm

Extended wire



Short Code	LS8884
Part Number	3MT-008884-001
Description	UNIVERSAL Lambda Sensor
Type	Planar
No. of Wires	4
Cable Length	200 mm
Heater Resistance	9 - 10 Ohm



Short Code	LS8889
Part Number	3MT-008889-001
Description	UNIVERSAL Lambda Sensor
Type	Planar
No. of Wires	4
Cable Length	350 mm
Heater Resistance	9 - 10 Ohm



EXCLUSIVE FEATURES

HELLA PREMIUM LAMBDA SENSOR ASSEMBLY INSTRUCTIONS (UNIVERSAL APPLICATIONS)



[1] Cut wires off close to body of used sensor.



[2] Remove the end insulation of each wire.



[3] Insert terminal into crimp tool with open part in crimp tool cavity.



[4] Partially close crimp tool to hold terminal in place and insert closing rubber with smaller diameter.



[5] Insert wire into terminal (pass through the closing rubber).



[6] Press crimp tool to lock wire in terminal.



[7] Insert each terminal/wire into universal plug connector.



[8] Ensure good connection and wiring fitment in correct order.

REPLACEMENT AND INSTALLATION

Remove the old Lambda Sensor carefully / thread corrosion or oxidation can prove problematic. Use high temperature grease in the thread of the new Lambda Sensor, so it can easily be removed later.

Avoid hitting or dropping the Lambda Sensor because the ceramic parts can be damaged.



[9] Insert red guide into connector.



[10] Clip the connector into the universal plug to complete process.

HELLA UNIVERSAL PREMIUM LAMBDA SENSOR RANGE

GENERAL INFORMATION

Thread	M18x1.5	Maximum working temperature	1 000°C
Hex	22 mm	Torque	40 - 60 Nm
Initial working temperature	300°C without internal heater 150°C with internal heater	Input Voltage of the heater	12 to 14 volts
		Stock keeping conditions	Temperature: -40°C to 100°C Humidity: 0 to 60%

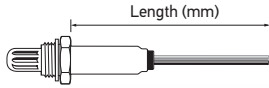

Short Code	LS7001
Part Number	3MT-007001-001
Description	UNIVERSAL Premium Lambda Sensor
Type	Finger
No. of Wires	1
Cable Length	200 mm



Short Code	LS7002
Part Number	3MT-007002-001
Description	UNIVERSAL Premium Lambda Sensor
Type	Finger
No. of Wires	2
Cable Length	200 mm



Short Code	LS7003
Part Number	3MT-007003-001
Description	UNIVERSAL Premium Lambda Sensor
Type	Finger
No. of Wires	3
Cable Length	200 mm
Heater Resistance	3 - 6 Ohm



Short Code	LS7004
Part Number	3MT-007004-001
Description	UNIVERSAL Premium Lambda Sensor
Type	Finger
No. of Wires	4
Cable Length	200 mm
Heater Resistance	3 - 6 Ohm

Extended wire



Short Code	LS8004
Part Number	3MT-008004-001
Description	UNIVERSAL Premium Lambda Sensor
Type	Planar
No. of Wires	4
Cable Length	200 mm
Heater Resistance	9 - 10 Ohm



Short Code	LS8009
Part Number	3MT-008009-001
Description	UNIVERSAL Premium Lambda Sensor
Type	Planar
No. of Wires	4
Cable Length	350 mm
Heater Resistance	9 - 10 Ohm

HELLA Automotive South Africa (Pty) Ltd.

P O Box 6130
Moselville, Uitenhage,
SOUTH AFRICA
6230

Sales Telephone: +27 (0) 41 996 5700

Sales Telefax: +27 (0) 41 996 5720

<http://www.hella.co.za>

© HELLA KGaA Hueck & Co., Lippstadt

PN: 6-001 07.2011

Printed in South Africa